

## **Appendix A : Uisce Éireann Statement of Design Acceptance**

Chamindu Goonewardena  
DBFL Consulting Engineers  
Ormond House  
Upper Ormond Quay  
Dublin 7  
D07W704

**Uisce Éireann**  
Bosca OP 448  
Oifig Sheachadta na  
Cathrach Theas  
Cathair Chorcaí

**Uisce Éireann**  
PO Box 448  
South City  
Delivery Office  
Cork City

[www.water.ie](http://www.water.ie)

14 May 2026

**Re: Design Submission for Site at, Whitestown Road, Dublin, Dublin  
(the “Development”)  
(the “Design Submission”) / Connection Reference No: CDS25005245**

Dear Chamindu Goonewardena,

Many thanks for your recent Design Submission.

We have reviewed your proposal for the connection(s) at the Development. Based on the information provided, which included the documents outlined in Appendix A to this letter, Uisce Éireann has no objection to your proposals.

This letter does not constitute an offer, in whole or in part, to provide a connection to any Uisce Éireann infrastructure. Before you can connect to our network you must sign a connection agreement with Uisce Éireann. This can be applied for by completing the connection application form at [www.water.ie/connections](http://www.water.ie/connections). Uisce Éireann’s current charges for water and wastewater connections are set out in the Water Charges Plan as approved by the Commission for Regulation of Utilities (CRU)([https://www.cru.ie/document\\_group/irish-waters-water-charges-plan-2018/](https://www.cru.ie/document_group/irish-waters-water-charges-plan-2018/)).

You the Customer (including any designers/contractors or other related parties appointed by you) is entirely responsible for the design and construction of all water and/or wastewater infrastructure within the Development which is necessary to facilitate connection(s) from the boundary of the Development to Uisce Éireann’s network(s) (the “**Self-Lay Works**”), as reflected in your Design Submission. Acceptance of the Design Submission by Uisce Éireann does not, in any way, render Uisce Éireann liable for any elements of the design and/or construction of the Self-Lay Works.

If you have any further questions, please contact your Uisce Éireann representative:

Name: Antonio Garzón Mielgo

Email: [antonio.garzonmielgo@water.ie](mailto:antonio.garzonmielgo@water.ie)

Yours sincerely,

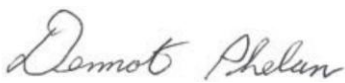

**Dermot Phelan**  
**Connections and Developer Services**

**Stiúirthóirí / Directors:** Jerry Grant (Cathaoirleach / Chairperson), Niall Gleeson (POF / CEO), Douglas Millican, Michael Nolan, Patricia King, Eileen Maher, Cathy Mannion, Michael Walsh, Rena O’Sullivan and Orlagh Nevin.

**Oifig Chláraithe / Registered Office:** Teach Colvill, 24-26 Sráid Thalbóid, Baile Átha Cliath 1, D01 NP86 / Colvill House, 24-26 Talbot Street, Dublin, Ireland D01NP86

Is cuideachta ghníomhaíochta ainmnithe atá faoi theorainn scaireanna é Uisce Éireann / Uisce Éireann is a designated activity company, limited by shares. Cláraithe in Éirinn Uimh.: 530363 / Registered in Ireland No.: 530363.

## Appendix A

### Document Title & Revision

- 240192-X-05-Z00-XXX-DR-DBFL-CE-1300 Drainage Layout Rev 1
- 240192-X-05-X-XXX-DR-DBFL-CE-3331 Foul Sewer Longitudinal Sections Rev 1
- X-93-Z00-XXX-DR-DBFL-CE-1400 Watermain Layout Rev 1

### Standard Details/Code of Practice Exemption:

1. *Uisce Éireann notes that the diameter indicated for the foul sewer between manholes F3 and F4 is inconsistent with the proposed network and is likely a drafting error. The applicant shall review and amend the pipe diameter and submit updated drawings reflecting this correction at Connection Application stage.*

### Additional Comments

The design submission will be subject to further technical review at connection application stage.

Uisce Éireann cannot guarantee that its Network in any location will have the capacity to deliver a particular flow rate and associated residual pressure to meet the requirements of the relevant Fire Authority, see Section 1.17 of Water Code of Practice.

Storm water generated from the site shall not be discharged to the Uisce Éireann wastewater network.

The proposed basement car park shall be designed such that surface water from the site and/or surrounding areas cannot flow into the basement.

Any wastewater arising within the basement car park (including runoff potentially contaminated by hydrocarbons) shall be collected and pumped to ground level and discharged by gravity to the Uisce Éireann network via an appropriately designed petrol interceptor.

For further information, visit [www.water.ie/connections](http://www.water.ie/connections)

Notwithstanding any matters listed above, the Customer (including any appointed designers/contractors, etc.) is entirely responsible for the design and construction of the Self-Lay Works. Acceptance of the Design Submission by Uisce Éireann will not, in any way, render Uisce Éireann liable for any elements of the design and/or construction of the Self-Lay Works.

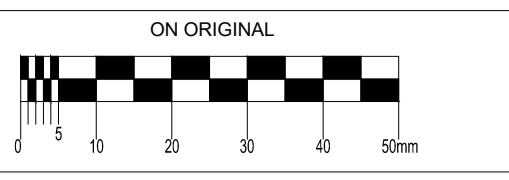
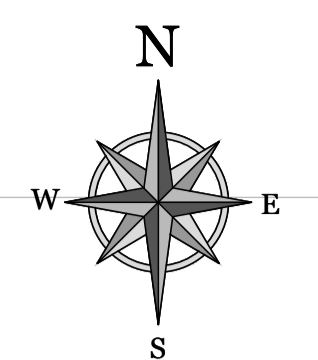
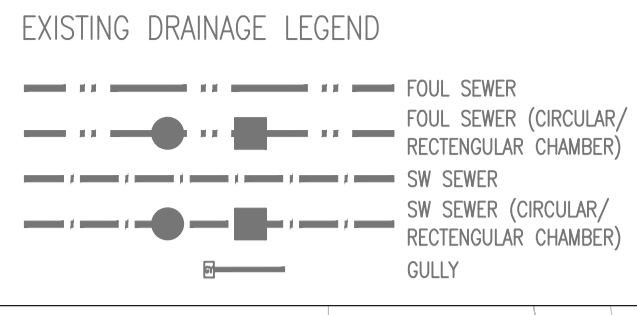

© COPYRIGHT OF THIS DRAWING IS RESERVED BY DBFL CONSULTING ENGINEERS. NO PART SHALL BE REPRODUCED OR TRANSMITTED WITHOUT THEIR WRITTEN PERMISSION.

NO CHANGES OF WHATSOEVER NATURE ARE TO BE MADE TO ANY DETAILS SET OUT OR CONTAINED IN ANY DBFL SPECIFICATIONS OR DRAWINGS UNLESS THE EXPRESS CONSENT HAS BEEN OBTAINED IN ADVANCE, IN WRITING, FROM DBFL.

- GENERAL NOTES:**
- ALL DRAWINGS TO BE CHECKED BY CONTRACTOR ON SITE AND ENGINEER INFORMED OF DISCREPANCIES BEFORE WORK COMMENCES.
  - ALL DIMENSIONS AND LEVELS ARE IN METRES UNLESS NOTED OTHERWISE.
  - ALL LEVELS ARE IN METERS AND ARE RELATED TO ORDINANCE DATUM. CO-ORDINATES RELATE TO ITM (IRISH TRANSVERSE MERCATOR).
  - CONTRACTOR SHALL SATISFY HIMSELF AS TO THE ACCURACY OF PAVEMENT LEVELS ON SITE PRIOR TO COMMENCEMENT OF WORKS ON SITE.
  - ALL WASTEWATER INFRASTRUCTURE INCLUDING FOUL SEWERS, CONNECTIONS AND MANHOLES TO SAME SHALL COMPLY WITH AND BE CONSTRUCTED IN ACCORDANCE WITH THE IRISH WATER CONNECTION AND DEVELOPER SERVICES WASTEWATER INFRASTRUCTURE STANDARD DETAILS DOCUMENT (W-CDS-5030-01).
  - FOUL SEWERS PIPE MATERIAL TO BE IN ACCORDANCE WITH SECTION 3.13 OF THE IRISH WATER CODE OF PRACTICE.
  - SURFACE WATER SEWER PIPE MATERIAL TO BE CLASS H CONCRETE TO EN1916 & IS 6 2004 IN ACCORDANCE WITH THE GREATER DUBLIN REGIONAL CODE OF PRACTICE FOR DRAINAGE WORKS.
  - LOCATION AND INVERT LEVELS OF EXISTING MANHOLES AND OUTFALL POINTS, TO BE VERIFIED BY CONTRACTOR PRIOR TO COMMENCEMENT OF DRAINAGE WORKS.
  - ALL COVER LEVELS TO MATCH FINISHED ROAD/VERGE/FOOTPATH/ CYCLETRACK LEVELS UNLESS OTHERWISE STATED.
  - ALL SURFACE WATER DRAINAGE WORKS/CONNECTIONS TO COMPLY WITH THE REQUIREMENTS OF THE LOCAL AUTHORITY.
  - CONTRACTOR TO INCLUDE FOR CCTV SURVEY OF ALL FOUL & SURFACE WATER SEWERS DRAINAGE UPON COMPLETION OF SAME.
  - MANHOLE COVERS IN LANDSCAPED AREAS TO BE SURROUNDED BY A CONCRETE PLINTH, 200MM ALL ROUND AND 100MM DEEP FORMED WITH C20/25 CONCRETE, 20MM AGGREGATE SIZE, BEDDED IN CLASS 8/4 MATERIAL.

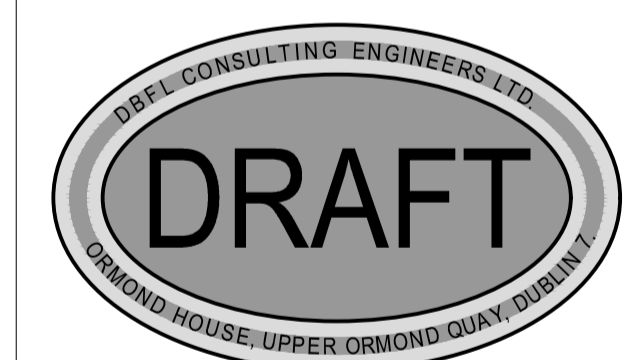
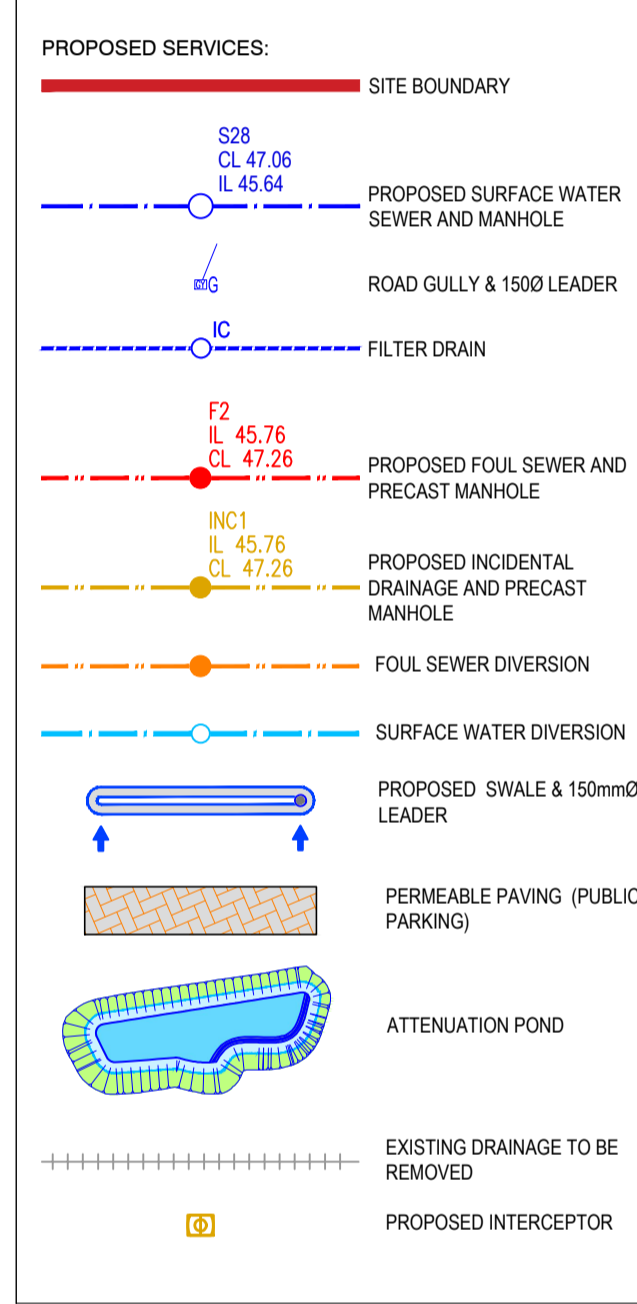

1	14-04-2026	STAGE 3 LRD DRAFT SUBMISSION	PV	NCG
0	13-02-2026	STAGE 2 LRD SUBMISSION	PV	NCG
rev	date	description	by	chkd.

**DBFL CONSULTING ENGINEERS**

T: +353 1 400 4000 | E: info@dbfl.ie | W: www.dbfl.ie

DUBLIN | CORK | GALWAY | WATERFORD

project ref.  
**SITE AT WHITESTOWN WAY - TALLAGHT**

drawing title  
**DRAINAGE LAYOUT**

client  
**ARP 4.2 SUSTAINABLE COMMUNITIES (IRELAND) FUND**

designed by	author	scale	sheet size
NCG	CK	1:500	A1
drawing no.	revision		
240192-X-05-Z00-XXX-DR-DBFL-CE-1300			1

ORDNANCE SURVEY IRELAND LICENCE  
No CYAL50276885  
© ORDNANCE SURVEY IRELAND  
GOVERNMENT OF IRELAND

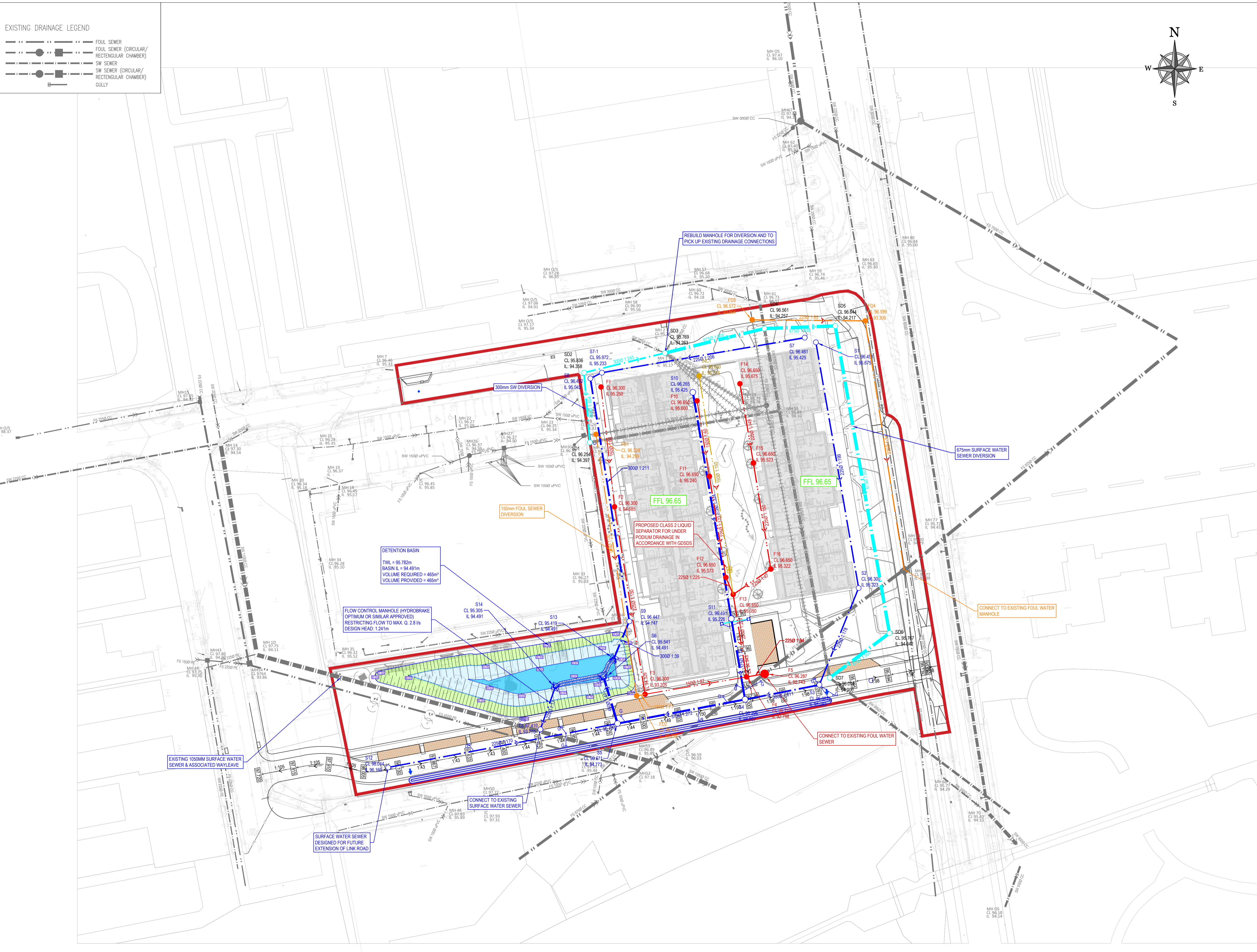

SCALE: H 1:500,V 1:100. DATUM: 90.000

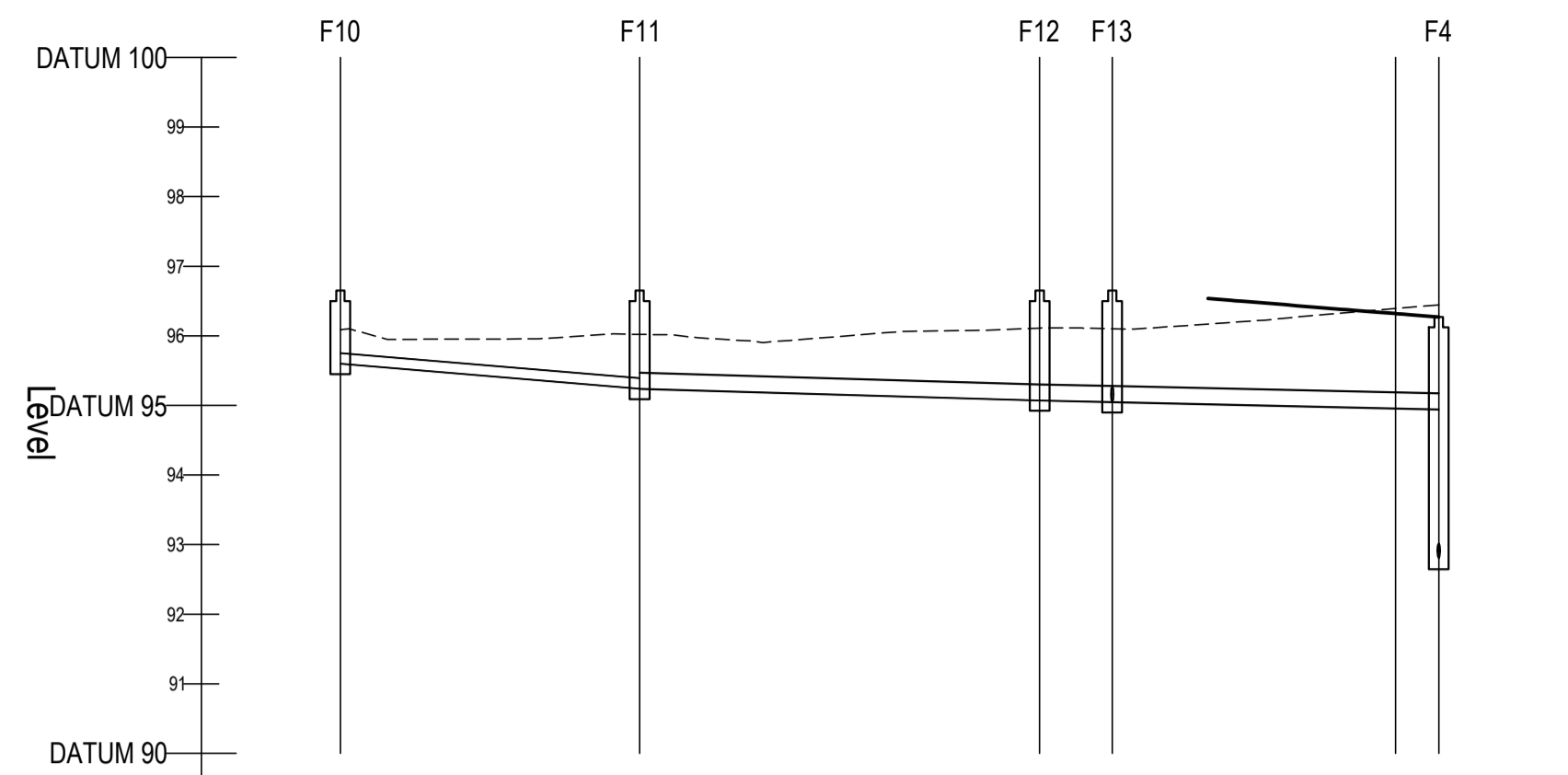

COVER LEVEL		96.600		96.650		96.650	96.650		96.650		96.270
INVERT LEVEL		96.600		96.240	96.240	96.650	96.073	96.073	96.650	96.650	94.945
DEPTH (m)		1.000		1.410			1.577	1.600			3.472
DISTANCE (m)			21.51		28.75		5.22		23.47		
PIPE SLOPE			1.60		1.172		1.225		1.225		
PIPE SIZE											

SCALE: H 1:500,V 1:100. DATUM: 90.000

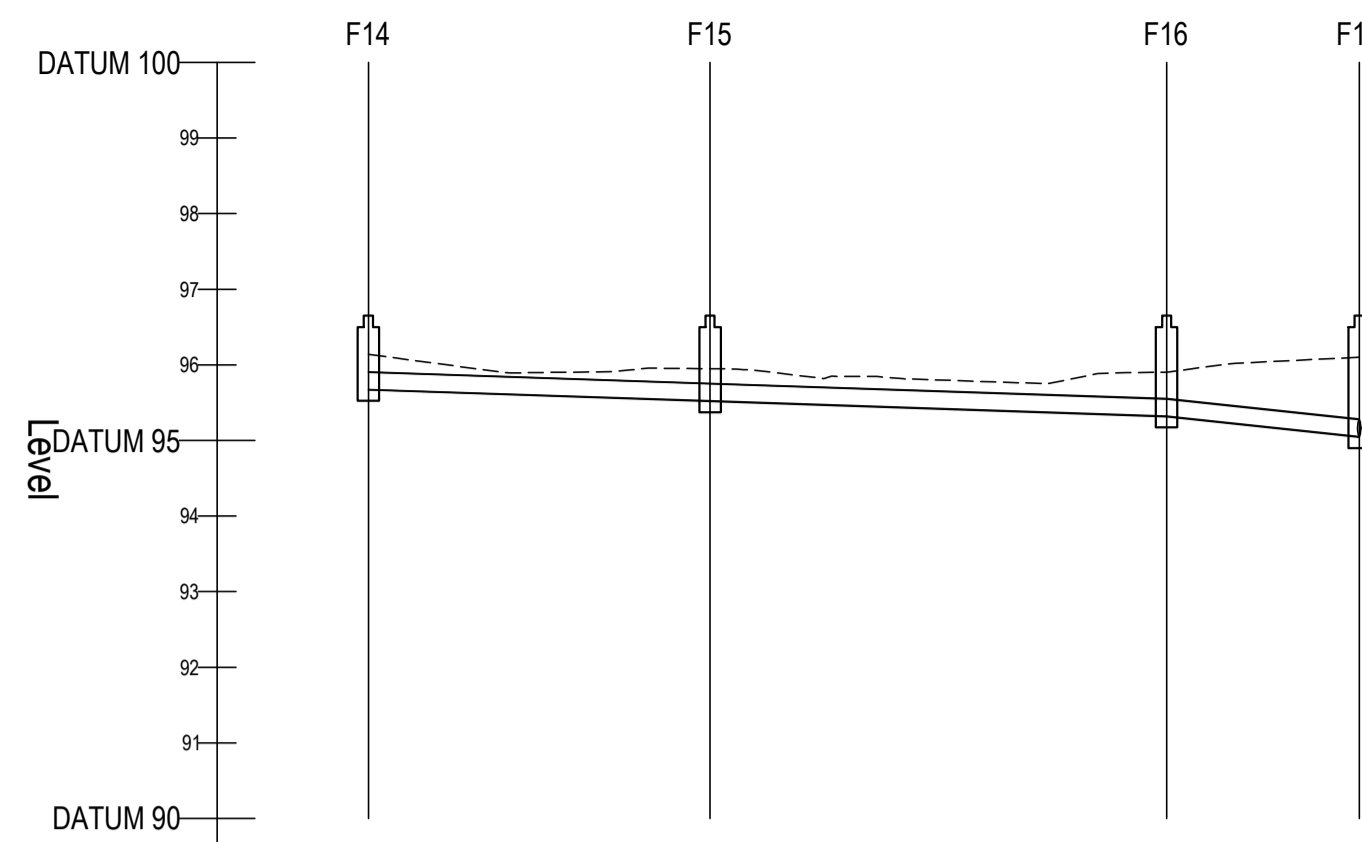

COVER LEVEL		96.650		96.650		96.650		96.650
INVERT LEVEL		96.675		96.523	96.523	96.322	96.322	96.650
DEPTH (m)		0.975		1.127		1.328	1.328	1.600
DISTANCE (m)			22.60		30.19		12.74	
PIPE SLOPE			1.149		1.150		1.47	
PIPE SIZE			225mm		225mm		225mm	

SCALE: H 1:500,V 1:100. DATUM: 90.000

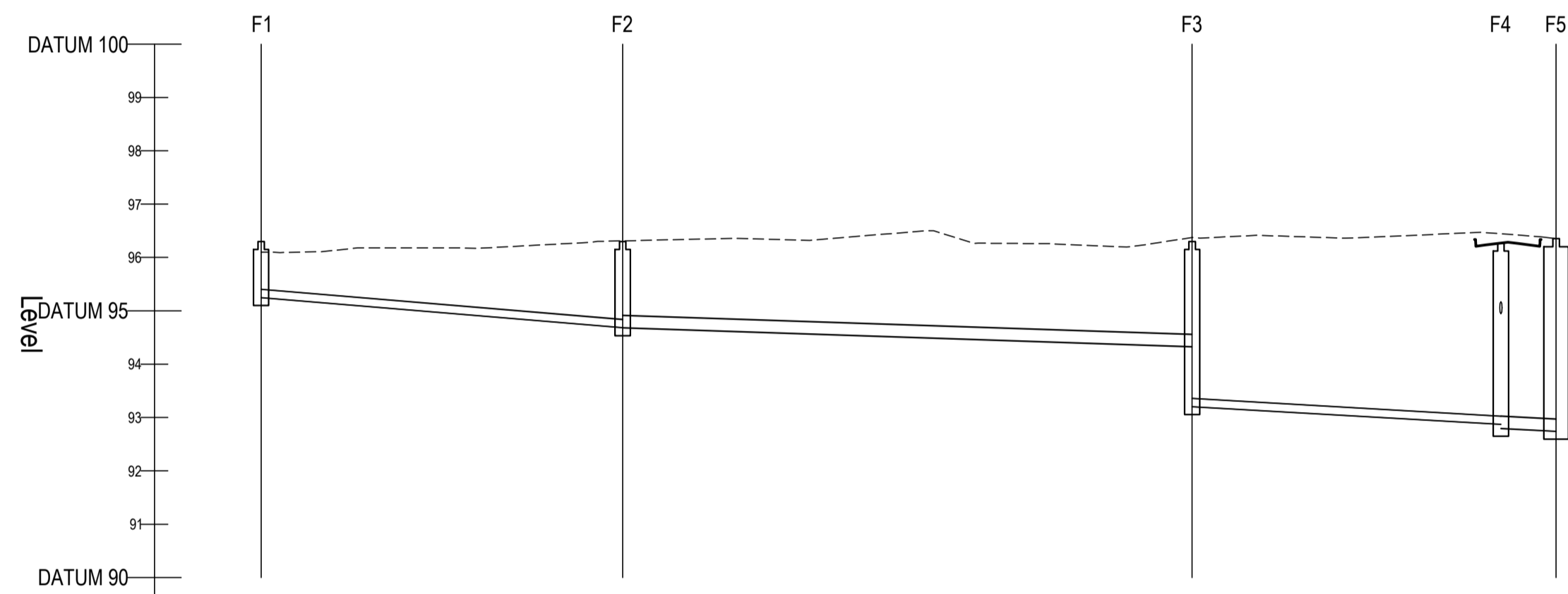

COVER LEVEL		96.300		96.300		96.300		96.270	96.352
INVERT LEVEL		95.250		94.855	94.855	94.329	93.205	92.873	92.713
DEPTH (m)		1.050		1.445		3.095		3.427	3.609
DISTANCE (m)			33.87			53.35		28.93	5.17
PIPE SLOPE			1.60			1.150		1.87	1.94
PIPE SIZE			150mm			225mm		150mm	225mm

SCALE: H 1:500,V 1:100. DATUM: 90.000

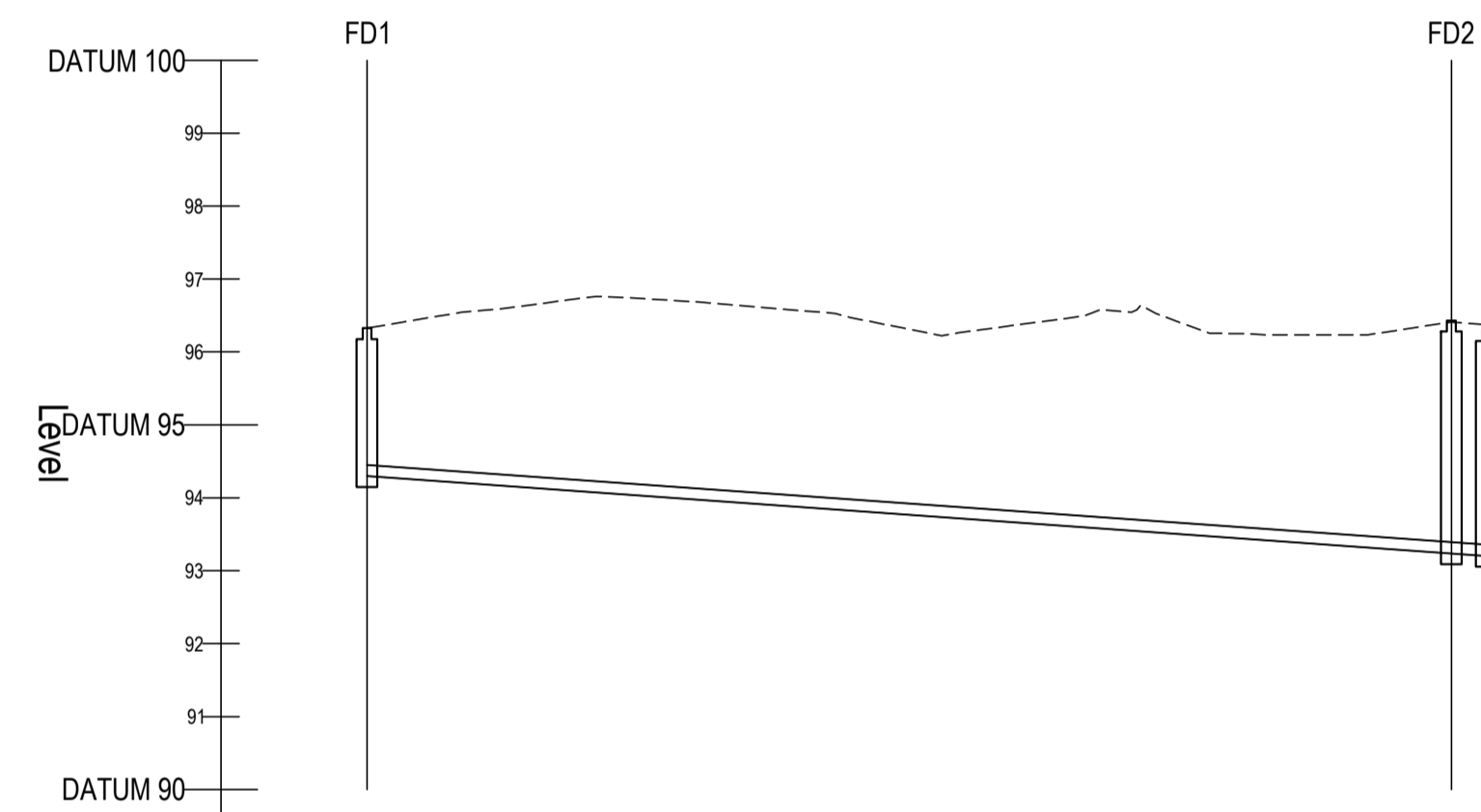

COVER LEVEL		96.305		96.431
INVERT LEVEL		94.299		93.239
DEPTH (m)		2.027		3.192
DISTANCE (m)			74.33	2.40
PIPE SLOPE			1.70	1.71
PIPE SIZE			150mm	150mm

SCALE: H 1:500,V 1:100. DATUM: 90.000

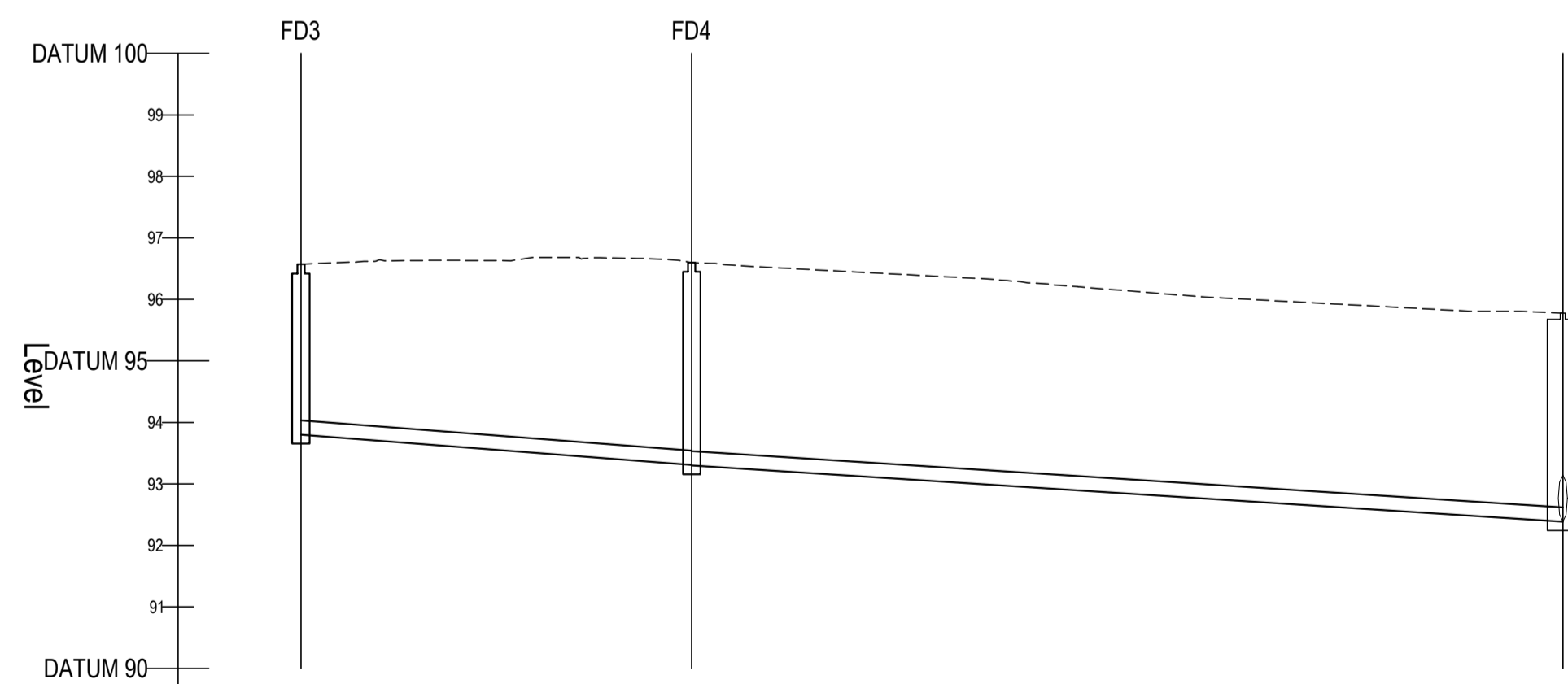

COVER LEVEL		95.572		95.599
INVERT LEVEL		93.304		93.312
DEPTH (m)		2.268		3.294
DISTANCE (m)			31.76	70.81
PIPE SLOPE			1.65	1.77
PIPE SIZE			225mm	225mm

SCALE: H 1:500,V 1:100. DATUM: 90.000

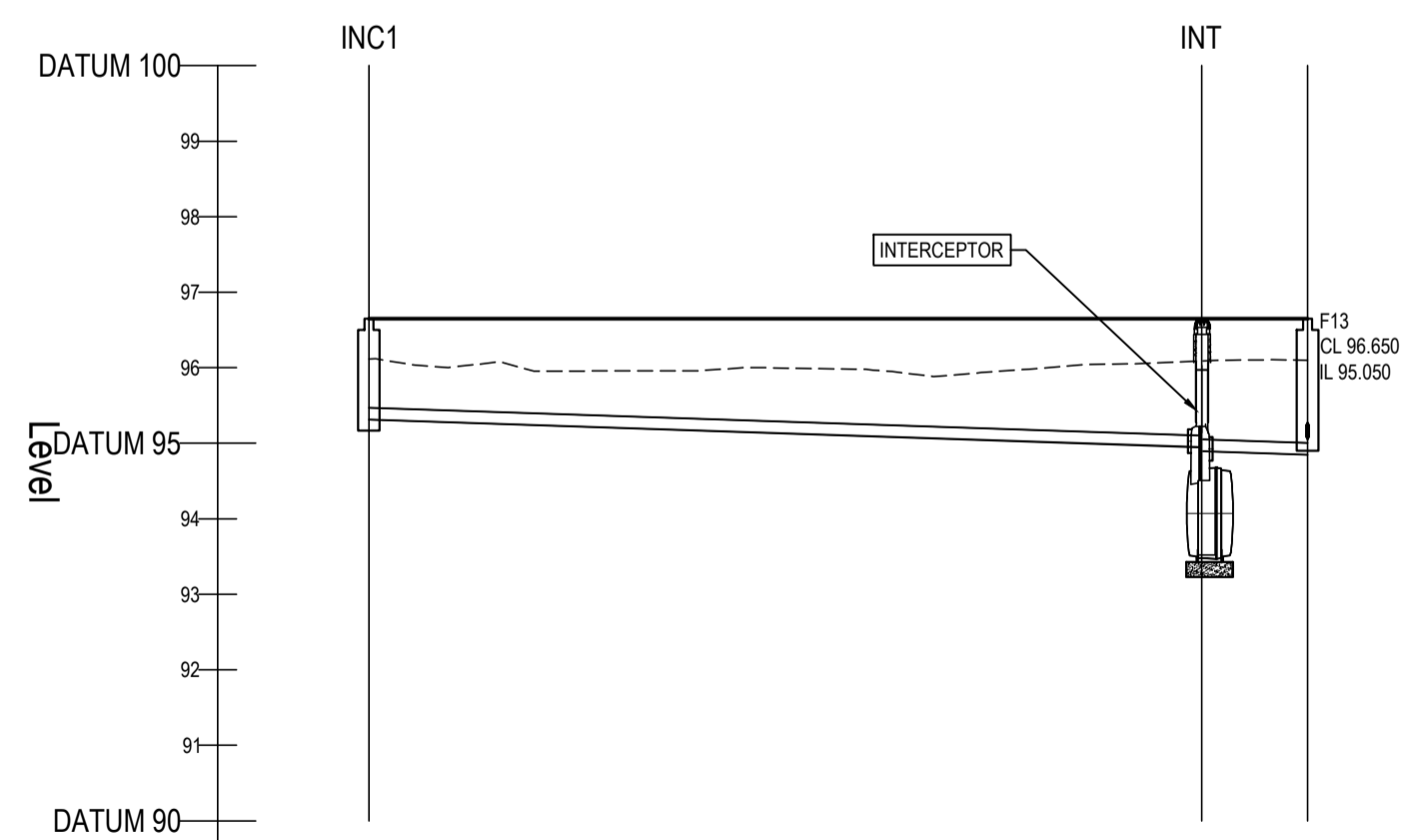

COVER LEVEL		96.650		95.114
INVERT LEVEL		95.316		94.948
DEPTH (m)		1.334		777
DISTANCE (m)			55.13	7.00
PIPE SLOPE			1.150	1.150
PIPE SIZE			150mm	150mm



© COPYRIGHT OF THIS DRAWING IS RESERVED BY DBFL CONSULTING ENGINEERS. NO PART SHALL BE REPRODUCED OR TRANSMITTED WITHOUT THEIR WRITTEN PERMISSION.  
NO CHANGES OF WHATSOEVER NATURE ARE TO BE MADE TO ANY DETAILS SET OUT OR CONTAINED IN ANY DBFL SPECIFICATIONS OR DRAWINGS UNLESS THE EXPRESS CONSENT HAS BEEN OBTAINED IN ADVANCE, IN WRITING, FROM DBFL.

- ALL DRAWINGS TO BE CHECKED BY CONTRACTOR ON SITE AND ENGINEER INFORMED OF DISCREPANCIES BEFORE WORK COMMENCES
- ALL LEVELS ARE IN METRES AND ARE RELATED TO ORDNANCE DATUM
- CONTRACTOR SHALL SATISFY THEMSELVES AS TO THE ACCURACY OF PAVEMENT LEVELS ON SITE PRIOR TO COMMENCEMENT OF WORKS ON SITE
- ALL WORKS TO BE CONSTRUCTED IN ACCORDANCE WITH THE NRA SPECIFICATION FOR ROAD WORKS UNLESS NOTED OTHERWISE
- THIS DRAWING IS FOR PLANNING PURPOSES ONLY
- MANHOLE COVER LEVELS ARE TO CONFORM WITH FINISHED ROAD AND PATH LEVELS
- WHERE COVER TO PIPE IS LESS THAN 100mm (ROAD/PATH/VERGE) OR 900mm (OPEN SPACE) SURROUND PIPE IN MINIMUM 150mm CONCRETE

KEY

----- EXISTING GROUND PROFILE  
————— PROPOSED GROUND PROFILE

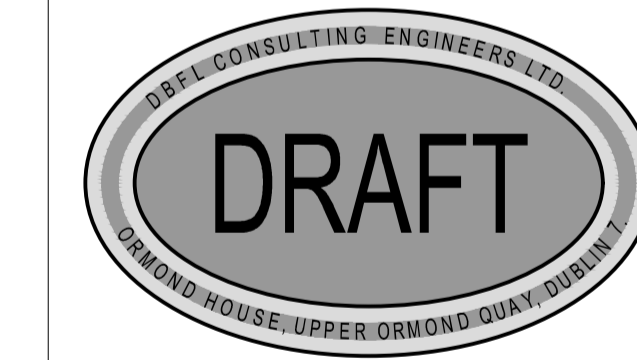

1	14-04-2026	STAGE 3 LRD DRAFT SUBMISSION	PV	NGC
0	13-02-2026	STAGE 2 LRD SUBMISSION	PV	NGC
rev	date	description	by	chkd.

STATUS CODES  
purpose acceptance  
P3 - PLANNING PERMISSION S - ISSUED

**DBFL**  
CONSULTING ENGINEERS  
T: +353 1 400 4000 | E: info@dbfl.ie | W: www.dbfl.ie  
DUBLIN | CORK | GALWAY | WATERFORD

project ref.  
**SITE AT WHITESTOWN WAY - TALLAGHT**  
drawing title  
**FOUL SEWER LONGITUDINAL SECTIONS**

client  
**ARP 4.2 SUSTAINABLE COMMUNITIES (IRELAND) FUND**

designed by	author	scale	sheet size
NGC	PV	AS SHOWN	A1
drawing no.		revision	
240192-X-05-X-XXX-DR-DBFL-CE-3331		1	

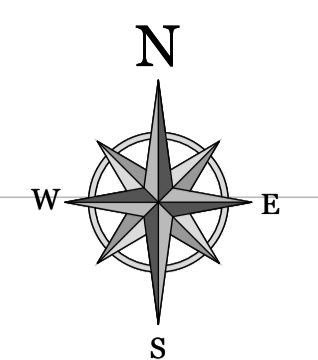
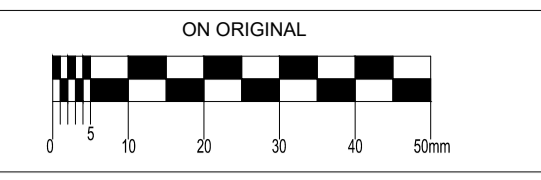

© COPYRIGHT OF THIS DRAWING IS RESERVED BY DBFL CONSULTING ENGINEERS. NO PART SHALL BE REPRODUCED OR TRANSMITTED WITHOUT THEIR WRITTEN PERMISSION.

NO CHANGES OF WHATSOEVER NATURE ARE TO BE MADE TO ANY DETAILS SET OUT OR CONTAINED IN ANY DBFL SPECIFICATIONS OR DRAWINGS UNLESS THE EXPRESS CONSENT HAS BEEN OBTAINED IN ADVANCE, IN WRITING, FROM DBFL.

- GENERAL NOTES:
1. ALL DRAWINGS TO BE CHECKED BY CONTRACTOR ON SITE AND ENGINEER INFORMED OF DISCREPANCIES BEFORE WORK COMMENCES.
  2. THE CONTRACTOR SHALL SATISFY THEMSELVES AS TO THE ACCURACY OF EXISTING DRAINAGE LEVELS AND LOCATION OF EXISTING SERVICES ON SITE PRIOR TO COMMENCEMENT OF WORKS ON SITE.
  3. ALL DIMENSIONS AND LEVELS ARE IN METERS AND ARE RELATED TO ORDINANCE DATUM. CO-ORDINATES RELATE TO IRISH TRANSVERSE MERCATOR.
  4. ALL WATERMANS VALVES AND FITTINGS SHALL BE CONSTRUCTED IN ACCORDANCE WITH THE IRISH WATER STANDARD DETAILS AND IRISH WATER CODE OF PRACTICE FOR WATER INFRASTRUCTURE.
  5. ALL WATERMANS SHALL BE HDPE, PE100, SDR17 TO IS EN 12201 PART 2:2011 AND IS EN 12201-3:2011.
  6. CONNECTION BETWEEN EXISTING AND PROPOSED WATERMANS TO BE CARRIED OUT IN ACCORDANCE WITH IRISH WATER STANDARD DETAILS STD-W-03 TO STD-W-10.
  7. ANCHOR BLOCKS TO BE POSITIONED AT DEAD ENDS, TEES, BENDS AND AT EACH SIDE OF HYDRANTS AND VALVES IN ACCORDANCE WITH THE REQUIREMENTS OF IRISH WATER STANDARD DETAIL STD-W-28 (WATER MAIN THRUST AND SUPPORT BLOCKS DISMANTLING JOINTS TO BE INSTALLED AT EACH SLUICE VALVE AS PER IRISH WATER STANDARD DETAIL STD-W-15).
  8. CONNECTION TO INDIVIDUAL HOUSES IN ACCORDANCE WITH IRISH WATER STD-W-03.
  9. INSTALLATION OF SLUICE VALVES, AIR VALVES AND HYDRANTS SHALL BE IN ACCORDANCE WITH IRISH WATER STANDARD DETAILS STD-W-14 TO STD-W-23.
  10. MARKER POSTS AND PLATES ARE TO BE PROVIDED IN ACCORDANCE WITH IRISH WATER STANDARD DETAIL STD-W-27.
  11. CONNECTION TO EXISTING WATERMANS TO BE COORDINATED BY THE CONTRACTOR WITH IRISH WATER AND/OR THE LOCAL AUTHORITY.
  12. CONTRACTOR TO LIAISE WITH IRISH WATER AND /OR THE LOCAL AUTHORITY AS REQUIRED REGARDING TESTING, CLEANSING AND STERILISATION OF WATERMANS.
  13. WATERMANS TO BE PRESSURE TESTED IN ACCORDANCE WITH THE REQUIREMENTS OF IRISH WATER AND IGA 4-01-03, GUIDE TO TESTING OF PRESSURE PIPES AND FITTINGS FOR USE BY PUBLIC WATER SUPPLIERS, OCTOBER 2015. A FORMAL TEST REPORT SHALL BE SUBMITTED TO THE ENGINEER DETAILING THE TEST CARRIED OUT.
  14. ALL AIR VALVES AND HYDRANTS COVERS, WHERE LOCATED IN GRASS AREAS, SHALL BE SURROUNDED BY A CONCRETE FLINTH 200MM ALL ROUND AND 100MM DEEP FORMED WITH C20/25 CONCRETE, 20MM AGGREGATE SIZE, BEDDED IN CLAUSE 804 MATERIAL. THE FLINTH SHALL INCORPORATE MILD STEEL REINFORCEMENT LINKS AND SHALL HAVE A BULL-NOSE FINISH AROUND ITS EXTERNAL PERIMETER.
  15. ALL WATERMANS PIPE MATERIAL TO BE IN COMPLIANCE WITH IRISH WATER WATER CODE OF PRACTICE.

LEGEND

- SITE BOUNDARY
- PROPOSED 125mm OD SDR17 PE-100 WATERMAIN
- PROPOSED 180mm OD SDR17 PE-100 WATERMAIN
- EXISTING WATERMAIN
- EXISTING FIRE HYDRANT
- PROPOSED 32mm Ø CONNECTION BOUNDARY BOX FOR RETAIL / CRECHE AS PER UE STD-W-26G.
- SLUICE VALVES AS PER IRISH WATER STANDARD DETAILS STD-W-14/15
- HYDRANT AS PER IRISH WATER STANDARD DETAIL STD-W-16/18
- AIR VALVE AS PER IRISH WATER STANDARD DETAILS STD-W-20 / 21 / 22 / 23
- WASH OUT HYDRANT (STD-W-30A)
- TEMPORARY 'DEAD-END' FOR FUTURE DEVELOPMENT AS PER IRISH WATER STANDARD DETAILS STD-W-05
- 46m OFFSET FROM HYDRANT
- PROPOSED ROAD LEVELS
- PROPOSED FINISH FLOOR LEVEL



1	12-05-2026	STAGE 3 LRD DRAFT SUBMISSION	PV	NGG
0	13-02-2026	STAGE 2 LRD SUBMISSION	GK	NGG
rev	date	description	by	chkd.

STATUS CODES

purpose acceptance  
 P3 - PLANNING PERMISSION S - ISSUED

**DBFL**  
 CONSULTING ENGINEERS

T : + 353 1 400 4000 | E: info@dbfl.ie | W: www.dbfl.ie

DUBLIN | CORK | GALWAY | WATERFORD

project ref.  
 SITE AT WHITESTOWN WAY - TALLAGHT

drawing title  
 WATERMAIN LAYOUT

client  
 ARP 4.2 SUSTAINABLE COMMUNITIES (IRELAND) FUND

designed by	author	scale	sheet size
NGG	GK	1:500	A1
drawing no.	revision		
240192-X-93-Z00-XXX-DR-DBFL-CE-1400	1		



CONNECTION OFF EXISTING 200mm WATERMAIN ON WHITESTOWN ROAD

32mm METERED CONNECTION (BOUNDARY BOX) FOR RETAIL/COMMERCIAL AS PER UE STD-W-26G. FACILITIES TO MEASURE UNIT IS TO BE PROVIDED IN A PUBLICLY ACCESSIBLE LOCATION.

32mm METERED CONNECTION (BOUNDARY BOX) FOR CRECHE AS PER UE STD-W-26G. FACILITIES TO MEASURE UNIT IS TO BE PROVIDED IN A PUBLICLY ACCESSIBLE LOCATION.

100mm METERED CONNECTION FOR RESIDENTIAL UNITS. FACILITIES TO MEASURE EACH INDIVIDUAL RESIDENTIAL UNIT TO BE PROVIDED IN A PUBLICLY ACCESSIBLE LOCATION.

WASHOUT HYDRANT WITH TEMPORARY DEAD END FOR FUTURE EXTENSION

FFL 96.65

FFL 96.65

WATERMAIN LOOP

## **Appendix B : Uisce Éireann Confirmation of Feasibility**

## CONFIRMATION OF FEASIBILITY

Chamindu Goonewardena

DBFL Consulting Eng.  
Ormond House  
Upper Ormond Quay  
Dublin 17  
D07W704  
Ireland

8 August 2025

**Uisce Éireann**  
Bosca OP 448  
Oifig Sheachadta na  
Cathrach Theas  
Cathair Chorcaí

**Uisce Éireann**  
PO Box 448  
South City  
Delivery Office  
Cork City

[www.water.ie](http://www.water.ie)

**Our Ref: CDS25005245 Pre-Connection Enquiry  
Site at, Whitestown road, Dublin**

Dear Applicant/Agent,

### **We have completed the review of the Pre-Connection Enquiry.**

Uisce Éireann has reviewed the pre-connection enquiry in relation to a Water & Wastewater connection for a Housing Development of 220 unit(s) at Site at, Whitestown road, Dublin, (the **Development**).

Based upon the details provided we can advise the following regarding connecting to the networks;

- **Water Connection** - Feasible without infrastructure upgrade by Uisce Éireann
- **Wastewater Connection** - Feasible without infrastructure upgrade by Uisce Éireann
- As per Uisce Éireann GIS records (please see Section B of this letter), Uisce Éireann assets are present on the site. The Developer must demonstrate that proposed structures and works will not inhibit access for maintenance or endanger structural or functional integrity of the assets during and after the works. For design submissions and queries related to diversion/build near or over, please contact UÉ Diversion Team via email address [diversions@water.ie](mailto:diversions@water.ie)

This letter does not constitute an offer, in whole or in part, to provide a connection to any Uisce Éireann infrastructure. Before the Development can be connected to our network(s) you must submit a connection application and be granted and sign a connection agreement with Uisce Éireann.

As the network capacity changes constantly, this review is only valid at the time of its completion. As soon as planning permission has been granted for the Development, a completed connection application should be submitted. The connection application is available at [www.water.ie/connections/get-connected/](http://www.water.ie/connections/get-connected/)

### Where can you find more information?

- **Section A** - What is important to know?
- **Section B** - Details of Uisce Éireann's Network(s)

**This letter is issued to provide information about the current feasibility of the proposed connection(s) to Uisce Éireann's network(s). This is not a connection offer and capacity in Uisce Éireann's network(s) may only be secured by entering into a connection agreement with Uisce Éireann.**

For any further information, visit [www.water.ie/connections](http://www.water.ie/connections), email [newconnections@water.ie](mailto:newconnections@water.ie) or contact 1800 278 278.

Yours sincerely,

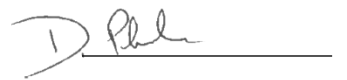
A handwritten signature in blue ink, appearing to read 'D. Phelan', is written over a horizontal line.

**Dermot Phelan**  
**Connections Delivery Manager**

## Section A - What is important to know?

What is important to know?	Why is this important?
<b>Do you need a contract to connect?</b>	<ul style="list-style-type: none"> <li>• Yes, a contract is required to connect. This letter does not constitute a contract or an offer in whole or in part to provide a connection to Uisce Éireann's network(s).</li> <li>• Before the Development can connect to Uisce Éireann's network(s), you must submit a connection application <u>and be granted and sign</u> a connection agreement with Uisce Éireann.</li> </ul>
<b>When should I submit a Connection Application?</b>	<ul style="list-style-type: none"> <li>• A connection application should only be submitted after planning permission has been granted.</li> </ul>
<b>Where can I find information on connection charges?</b>	<ul style="list-style-type: none"> <li>• Uisce Éireann connection charges can be found at: <a href="https://www.water.ie/connections/information/charges/">https://www.water.ie/connections/information/charges/</a></li> </ul>
<b>Who will carry out the connection work?</b>	<ul style="list-style-type: none"> <li>• All works to Uisce Éireann's network(s), including works in the public space, must be carried out by Uisce Éireann*.</li> </ul> <p>*Where a Developer has been granted specific permission and has been issued a connection offer for Self-Lay in the Public Road/Area, they may complete the relevant connection works</p>
<b>Fire flow Requirements</b>	<ul style="list-style-type: none"> <li>• The Confirmation of Feasibility does not extend to fire flow requirements for the Development. Fire flow requirements are a matter for the Developer to determine.</li> <li>• <b>What to do?</b> - Contact the relevant Local Fire Authority</li> </ul>
<b>Plan for disposal of storm water</b>	<ul style="list-style-type: none"> <li>• The Confirmation of Feasibility does not extend to the management or disposal of storm water or ground waters.</li> <li>• <b>What to do?</b> - Contact the relevant Local Authority to discuss the management or disposal of proposed storm water or ground water discharges.</li> </ul>
<b>Where do I find details of Uisce Éireann's network(s)?</b>	<ul style="list-style-type: none"> <li>• Requests for maps showing Uisce Éireann's network(s) can be submitted to: <a href="mailto:datarequests@water.ie">datarequests@water.ie</a></li> </ul>

<p><b>What are the design requirements for the connection(s)?</b></p>	<ul style="list-style-type: none"> <li>The design and construction of the Water &amp; Wastewater pipes and related infrastructure to be installed in this Development shall comply with <b><i>the Uisce Éireann Connections and Developer Services Standard Details and Codes of Practice</i></b>, available at <a href="http://www.water.ie/connections">www.water.ie/connections</a></li> </ul>
<p><b>Trade Effluent Licensing</b></p>	<ul style="list-style-type: none"> <li>Any person discharging trade effluent** to a sewer, must have a Trade Effluent Licence issued pursuant to section 16 of the Local Government (Water Pollution) Act, 1977 (as amended).</li> <li>More information and an application form for a Trade Effluent License can be found at the following link: <a href="https://www.water.ie/business/trade-effluent/about/">https://www.water.ie/business/trade-effluent/about/</a></li> </ul> <p>**trade effluent is defined in the Local Government (Water Pollution) Act, 1977 (as amended)</p>

## Section B – Details of Uisce Éireann’s Network(s)

The map included below outlines the current Uisce Éireann infrastructure adjacent the Development: To access Uisce Éireann Maps email

[datarequests@water.ie](mailto:datarequests@water.ie)

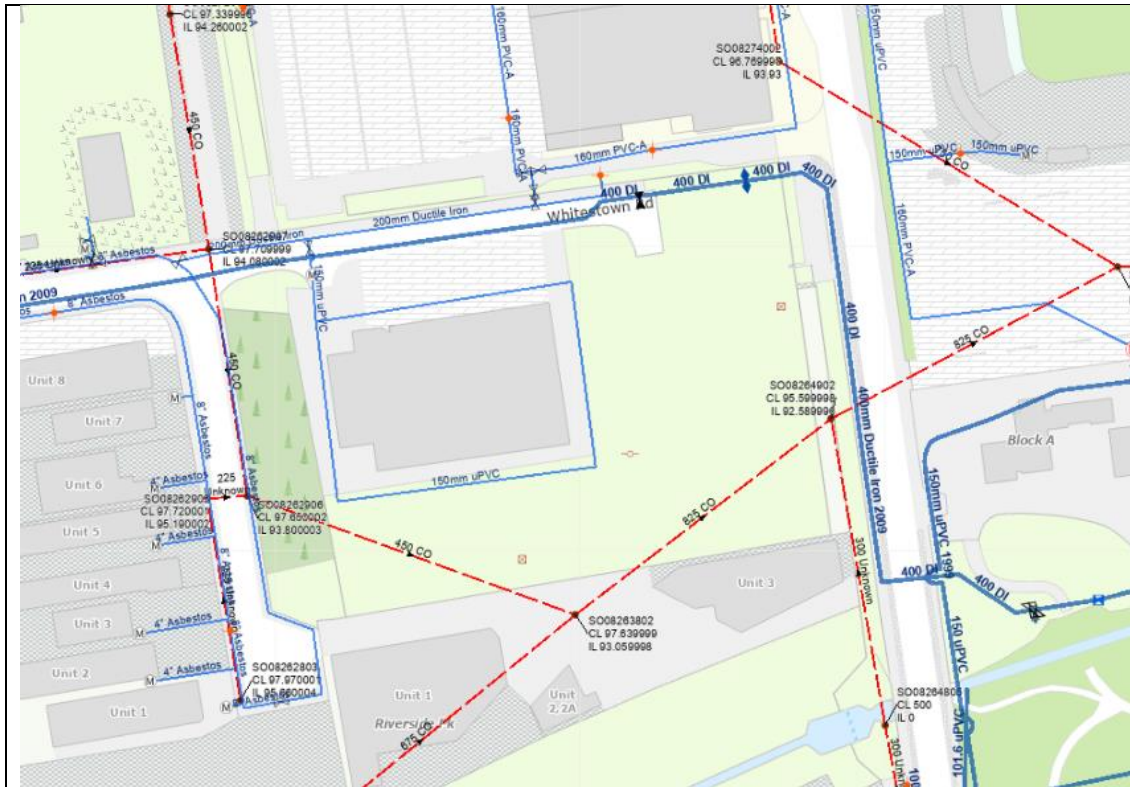

Reproduced from the Ordnance Survey of Ireland by Permission of the Government. License No. 3-3-34

**Note:** The information provided on the included maps as to the position of Uisce Éireann’s underground network(s) is provided as a general guide only. The information is based on the best available information provided by each Local Authority in Ireland to Uisce Éireann.

Whilst every care has been taken in respect of the information on Uisce Éireann’s network(s), Uisce Éireann assumes no responsibility for and gives no guarantees, undertakings or warranties concerning the accuracy, completeness or up to date nature of the information provided, nor does it accept any liability whatsoever arising from or out of any errors or omissions. This information should not be solely relied upon in the event of excavations or any other works being carried out in the vicinity of Uisce Éireann’s underground network(s). The onus is on the parties carrying out excavations or any other works to ensure the exact location of Uisce Éireann’s underground network(s) is identified prior to excavations or any other works being carried out. Service connection pipes are not generally shown but their presence should be anticipated.

## **Appendix C : Build Near Application Confirmation of Feasibility**

Ardstone Homes  
48 Fitzwilliam Square,  
Dublin 2, Dublin, Ireland

**Uisce Éireann**  
Teach Colvill  
24-26 Sráid Thalbóid  
Baile Átha Cliath 1  
D01 NP86  
Éire

21 January 2026

**Uisce Éireann**  
Colvill House  
24-26 Talbot Street  
Dublin 1  
D01 NP86  
Ireland

**T:** +353 1 89 25000  
**F:** +353 1 89 25001  
**[www.water.ie](http://www.water.ie)**

To whom it may concern,

**Re: Diversion Reference DIV25387 Whitestown, Tallaght, Dublin. Diversion enquiry. Subject to contract | Contract denied**

Uisce Éireann has reviewed your enquiry in relation to a building near of Uisce Éireann's sewer as part of the proposed Development at Whitestown, Tallaght in strict accordance with the drawing no. X-05-Z00-DTM-DR-DBFL-CE-1320.

Based upon the details you have provided with your enquiry and as assessed by Uisce Éireann, we wish to advise you that, subject to valid agreement/s being put in place, the proposed development can be facilitated.

If you have any further questions, please contact Jurica Matosevic from the diversions team on [jmatosevic@water.ie](mailto:jmatosevic@water.ie). For further information, visit [www.water.ie/connections](http://www.water.ie/connections).

Yours sincerely,



**Dermot Phelan**  
**Connections Delivery Manager**

## Appendix D : Qbar Calculations

PROJECT  
Whitestown Way Tallaght

JOB REF.  
240192

SUBJECT  
Surface Water Calculations - Permissible Site Discharge

Calc. Sheet No.  
1

Drawing ref. Calculations by  
MD

Checked by  
NG

Date  
13/02/2026

**DBFL**

### PERMISSIBLE SURFACE WATER DISCHARGE CALCULATIONS

#### Site Area

What is the overall site area?  Hectares (ha) Site is Less than 50 Hectares

#### Pre-Development Catchment Soil Characteristics

Are there different soil types present on the pre-developed site?

How many different soil types are present on the pre-developed site?

Catchment	This refers to the entire site area	1.10	
Area		1.10	Hectares (ha)
Drainage Group		1	Class
Depth to Impermeable Layers		1	Class
Permeability Group above Impermeable Layers		2	Class
Slope <sup>(6)</sup>		1	Class
SOIL Type		2	
SOIL Index		0.30	

SOIL	SOIL Value	SPR
1	0.15	0.10
2	0.30	0.30
3	0.40	0.37
4	0.45	0.47
5	0.50	0.53

Site SOIL Index Value

Site SPR Value

#### Post-Development Catchment Characteristics

Is the development divided into sub-catchments?

How many sub-catchments?

What is the overall site area for catchment?  Hectares (ha)

	Area (m <sup>2</sup> )	Runoff Coeff.	Effective Area (m <sup>2</sup> )	Effective Area After Urban Creep (m <sup>2</sup> )
Roof - Green Roof	1880	0.70	1316	1316
Roof	880	0.95	836	836
Podium Decks	1470	0.60	882	882
Roads and Footpaths - Draining to gullies	930	0.95	884	884
Roads and Footpaths - Draining to SuDS	880	0.80	704	704
Permeable Paving	2230	0.75	1673	1673
Grassed Areas	2810	0.15	422	422

Include Public Open Space in Effective Catchment Area?

Effective Catchment Area  m<sup>2</sup>

Effective Catchment Runoff Coefficient

#### Long-Term Storage

Is long-term Storage provided?

#### Permissible Site Discharge

What is the Standard Average Annual Rainfall (SAAR)?  mm From Met Eireann, Co-ordinates E308389 , N226960

Is the overall site area less than 50 hectares?  dar

<sup>5</sup>QBAR<sub>Rural</sub> calculated for 50 ha and linearly interpolated for area of site  Litres/sec

<sup>7</sup>Site Discharge =  Litres/sec

#### Notes and Formulae

- SOIL index value calculated from Flood Studies Report - The Classification of Soils from Winter Rainfall Acceptance Rate (Table 4.5).
- SPR value calculated from GSDSDS - Table 6.7.
- Rainfall depth for 100 year return period, 6 hour duration with additional 10% for climate change.
- Long-term storage Vol<sub>st</sub> (m<sup>3</sup>) = Rainfall.Area.10.[(PIMP/100)(0.8.α)+(1-PIMP/100)(β.SPR)-SPR]. (GSDSDS Section 6.7.3).  
Where long-term storage cannot be provided on-site due to ground conditions, Total Permissible Outflow is to be kept to QBAR<sub>(Rural)</sub>.
- Total Permissible Outflow - QBAR<sub>(Rural)</sub> calculated in accordance with GSDSDS - Regional Drainage Policies  
(Volume 2 - Chapter 6), i.e. QBAR(m<sup>3</sup>/s)=0.00108x(Area)<sup>0.89</sup>(SAAR)<sup>1.17</sup>(SOIL)<sup>2.17</sup> - For catchments greater than 50 hectares in area. Flow rates are linearly interpolated for areas smaller than 50hectares.
- Where Total Permissible Outflow is less than 2.0l/s and not achievable, use 2.0 l/s or closest value possible.
- QBAR multiplied by growth factors of 0.85 for 1 year, 2.1 for 30 year and 2.6 for 100 year return period events, from GSDSDS Figure C2.

## Appendix E : Drainage Network Calculations

**Design Settings**

Rainfall Methodology	FSR	Maximum Time of Concentration (mins)	30.00
Return Period (years)	2	Maximum Rainfall (mm/hr)	100.0
Additional Flow (%)	0	Minimum Velocity (m/s)	1.00
FSR Region	Scotland and Ireland	Connection Type	Level Soffits
M5-60 (mm)	18.500	Minimum Backdrop Height (m)	0.200
Ratio-R	0.242	Preferred Cover Depth (m)	1.200
CV	0.840	Include Intermediate Ground	✓
Time of Entry (mins)	4.00	Enforce best practice design rules	✓

**Simulation Settings**

Rainfall Methodology	FSR	Analysis Speed	Normal
Rainfall Events	Singular	Skip Steady State	x
FSR Region	Scotland and Ireland	Drain Down Time (mins)	720
M5-60 (mm)	18.500	Additional Storage (m³/ha)	0.0
Ratio-R	0.242	Starting Level (m)	
Summer CV	0.750	Check Discharge Rate(s)	x
Winter CV	0.840	Check Discharge Volume	x

**Storm Durations**

15 | 30 | 60 | 120 | 180 | 240 | 360 | 480 | 600 | 720 | 960 | 1440

Return Period (years)	Climate Change (CC %)	Additional Area (A %)	Additional Flow (Q %)
1	20	0	0
2	20	0	0
30	20	0	0
100	20	0	0

**Node S14 Online Hydro-Brake® Control**

Flap Valve	x	Objective	(HE) Minimise upstream storage
Replaces Downstream Link	x	Sump Available	✓
Invert Level (m)	94.695	Product Number	CTL-SHE-0076-2800-1270-2800
Design Depth (m)	1.270	Min Outlet Diameter (m)	0.100
Design Flow (l/s)	2.8	Min Node Diameter (mm)	1200

**Node S14 Pond Storage Structure**

Invert Level (m) 94.695 | Time to half empty (mins) | Analyse flow through structure x

**Inlets**

S13 | S6

Depth (m)	Area (m²)	Depth (m)	Area (m²)
0.000	232.9	1.270	1102.0

**Results for 1 year +20% CC Critical Storm Duration. Lowest mass balance: 99.95%**

Node Event	US Node	Peak (mins)	Level (m)	Depth (m)	Inflow (l/s)	Node Vol (m³)	Flood (m³)	Status
15 minute winter	S1	10	95.755	0.080	10.4	0.0908	0.0000	OK
15 minute winter	S2	11	95.426	0.103	17.0	0.1164	0.0000	OK
15 minute winter	S3	11	95.169	0.112	18.8	0.1265	0.0000	OK
1440 minute winter	S4	1080	95.120	0.225	3.0	0.3216	0.0000	OK
1440 minute winter	S5	1080	95.120	0.416	3.9	0.5950	0.0000	OK
1440 minute winter	S6	1080	95.120	0.449	3.8	0.0000	0.0000	OK
15 minute winter	S7	10	95.486	0.061	6.1	0.0694	0.0000	OK
15 minute winter	S7-1	10	95.281	0.137	20.9	0.1553	0.0000	OK
15 minute winter	S8	11	95.177	0.120	25.2	0.1356	0.0000	OK
1440 minute winter	S9	1080	95.120	0.347	4.9	0.3923	0.0000	SURCHARGED
15 minute winter	S10	10	95.464	0.039	2.7	0.0555	0.0000	OK
15 minute winter	S11	11	95.269	0.039	5.9	0.0565	0.0000	OK
15 minute winter	S12	11	96.054	0.051	5.1	0.0574	0.0000	OK
1440 minute winter	S13	1080	95.120	0.425	4.7	0.0000	0.0000	OK
1440 minute winter	S14	1080	95.117	0.422	4.5	161.8356	0.0000	SURCHARGED
1440 minute summer	S15	1200	94.682	0.039	2.6	0.0000	0.0000	OK
15 minute summer	S16	1	96.270	0.000	0.0	0.0000	0.0000	OK

Link Event (Upstream Depth)	US Node	Link	DS Node	Outflow (l/s)	Velocity (m/s)	Flow/Cap	Link Vol (m³)
15 minute winter	S1	1.000	S2	10.2	0.693	0.278	1.0486
15 minute winter	S2	1.001	S3	16.0	0.925	0.412	0.5873
15 minute winter	S3	1.002	S4	18.9	0.828	0.268	0.3182
1440 minute winter	S4	1.003	S5	2.9	0.358	0.026	3.2719
1440 minute winter	S5	1.004	S6	3.8	0.134	0.024	2.0443
15 minute winter	S7	4.000	S7-1	6.0	0.353	0.165	0.9864
15 minute winter	S7-1	4.001	S8	20.4	0.875	0.556	0.0574
15 minute winter	S8	4.002	S9	24.4	0.622	0.345	2.7105
1440 minute winter	S9	4.003	S13	4.7	0.368	0.067	0.8509
15 minute winter	S10	2.000	S11	2.5	0.414	0.023	0.3842
15 minute winter	S11	2.001	S4	5.6	0.290	0.024	0.5191
15 minute winter	S12	3.001	S5	4.4	0.666	0.111	0.4368
1440 minute winter	S14	5.000	S15	2.6	0.557	0.066	0.0414
15 minute summer	S16	3.000	S12	0.0	0.000	0.000	0.1488

**Results for 2 year +20% CC Critical Storm Duration. Lowest mass balance: 99.92%**

Node Event	US Node	Peak (mins)	Level (m)	Depth (m)	Inflow (l/s)	Node Vol (m <sup>3</sup> )	Flood (m <sup>3</sup> )	Status
15 minute winter	S1	10	95.764	0.089	12.5	0.1005	0.0000	OK
15 minute winter	S2	11	95.438	0.115	20.5	0.1304	0.0000	OK
1440 minute winter	S3	1110	95.186	0.129	2.1	0.1457	0.0000	OK
1440 minute winter	S4	1110	95.186	0.291	3.5	0.4162	0.0000	OK
1440 minute winter	S5	1110	95.186	0.482	4.5	0.6895	0.0000	SURCHARGED
1440 minute winter	S6	1110	95.186	0.515	4.3	0.0000	0.0000	OK
15 minute winter	S7	10	95.493	0.068	7.4	0.0767	0.0000	OK
15 minute winter	S7-1	10	95.298	0.154	25.3	0.1745	0.0000	OK
15 minute winter	S8	11	95.190	0.133	30.6	0.1508	0.0000	OK
1440 minute winter	S9	1110	95.186	0.413	5.8	0.4671	0.0000	SURCHARGED
15 minute winter	S10	10	95.467	0.042	3.2	0.0604	0.0000	OK
15 minute winter	S11	11	95.273	0.043	7.1	0.0616	0.0000	OK
15 minute winter	S12	11	96.059	0.056	6.1	0.0634	0.0000	OK
1440 minute winter	S13	1110	95.186	0.491	5.6	0.0000	0.0000	OK
1440 minute winter	S14	1110	95.183	0.488	5.0	198.1309	0.0000	SURCHARGED
240 minute winter	S15	184	94.682	0.039	2.6	0.0000	0.0000	OK
15 minute summer	S16	1	96.270	0.000	0.0	0.0000	0.0000	OK

Link Event (Upstream Depth)	US Node	Link	DS Node	Outflow (l/s)	Velocity (m/s)	Flow/Cap	Link Vol (m <sup>3</sup> )
15 minute winter	S1	1.000	S2	12.3	0.724	0.335	1.2125
15 minute winter	S2	1.001	S3	19.4	0.970	0.500	0.6786
1440 minute winter	S3	1.002	S4	2.1	0.462	0.030	0.5194
1440 minute winter	S4	1.003	S5	3.3	0.354	0.030	3.7952
1440 minute winter	S5	1.004	S6	4.3	0.140	0.027	2.0808
15 minute winter	S7	4.000	S7-1	7.3	0.372	0.201	1.1302
15 minute winter	S7-1	4.001	S8	24.8	0.933	0.676	0.0654
15 minute winter	S8	4.002	S9	29.5	0.649	0.418	3.1152
1440 minute winter	S9	4.003	S13	5.6	0.385	0.080	0.8509
15 minute winter	S10	2.000	S11	3.0	0.433	0.027	0.4356
15 minute winter	S11	2.001	S4	6.7	0.301	0.028	0.5993
15 minute winter	S12	3.001	S5	5.4	0.705	0.136	0.5024
1440 minute winter	S14	5.000	S15	2.6	0.557	0.066	0.0414
15 minute summer	S16	3.000	S12	0.0	0.000	0.000	0.1708

**Results for 30 year +20% CC Critical Storm Duration. Lowest mass balance: 99.67%**

Node Event	US Node	Peak (mins)	Level (m)	Depth (m)	Inflow (l/s)	Node Vol (m <sup>3</sup> )	Flood (m <sup>3</sup> )	Status
15 minute winter	S1	10	95.802	0.127	23.0	0.1433	0.0000	OK
15 minute winter	S2	11	95.502	0.179	37.8	0.2020	0.0000	OK
1440 minute winter	S3	1380	95.454	0.397	3.3	0.4490	0.0000	SURCHARGED
1440 minute winter	S4	1380	95.454	0.559	5.4	0.7999	0.0000	SURCHARGED
1440 minute winter	S5	1380	95.454	0.750	6.9	1.0732	0.0000	SURCHARGED
1440 minute winter	S6	1380	95.454	0.783	6.8	0.0000	0.0000	OK
15 minute winter	S7	10	95.519	0.094	13.6	0.1066	0.0000	OK
1440 minute winter	S7-1	1380	95.455	0.311	3.4	0.3514	0.0000	SURCHARGED
1440 minute winter	S8	1380	95.453	0.396	4.2	0.4478	0.0000	SURCHARGED
1440 minute winter	S9	1410	95.454	0.681	8.8	0.7700	0.0000	SURCHARGED
15 minute winter	S10	10	95.483	0.058	5.9	0.0824	0.0000	OK
1440 minute winter	S11	1380	95.454	0.224	0.9	0.3205	0.0000	OK
15 minute winter	S12	11	96.081	0.078	11.3	0.0887	0.0000	OK
1440 minute winter	S13	1380	95.454	0.759	8.7	0.0000	0.0000	OK
1440 minute winter	S14	1380	95.451	0.756	6.9	376.0709	0.0000	SURCHARGED
60 minute summer	S15	150	94.682	0.039	2.6	0.0000	0.0000	OK
15 minute summer	S16	1	96.270	0.000	0.0	0.0000	0.0000	OK

Link Event (Upstream Depth)	US Node	Link	DS Node	Outflow (l/s)	Velocity (m/s)	Flow/Cap	Link Vol (m <sup>3</sup> )
15 minute winter	S1	1.000	S2	22.7	0.825	0.620	1.9693
15 minute winter	S2	1.001	S3	35.8	1.121	0.921	1.0809
1440 minute winter	S3	1.002	S4	3.2	0.491	0.046	0.9789
1440 minute winter	S4	1.003	S5	5.1	0.347	0.046	4.1441
1440 minute winter	S5	1.004	S6	6.8	0.197	0.043	2.0808
15 minute winter	S7	4.000	S7-1	13.5	0.427	0.374	1.6059
1440 minute winter	S7-1	4.001	S8	3.4	0.541	0.093	0.0982
1440 minute winter	S8	4.002	S9	3.9	0.253	0.056	4.8913
1440 minute winter	S9	4.003	S13	8.7	0.426	0.123	0.8509
15 minute winter	S10	2.000	S11	5.7	0.525	0.052	0.6870
1440 minute winter	S11	2.001	S4	0.9	0.152	0.004	2.1302
15 minute winter	S12	3.001	S5	10.3	0.846	0.259	0.8007
1440 minute winter	S14	5.000	S15	2.6	0.557	0.066	0.0414
15 minute summer	S16	3.000	S12	0.0	0.000	0.000	0.2746

**Results for 100 year +20% CC Critical Storm Duration. Lowest mass balance: 99.13%**

Node Event	US Node	Peak (mins)	Level (m)	Depth (m)	Inflow (l/s)	Node Vol (m <sup>3</sup> )	Flood (m <sup>3</sup> )	Status
15 minute winter	S1	10	95.826	0.151	29.9	0.1709	0.0000	OK
15 minute winter	S2	11	95.596	0.273	49.3	0.3083	0.0000	SURCHARGED
1440 minute winter	S3	1410	95.587	0.530	4.0	0.5996	0.0000	SURCHARGED
1440 minute winter	S4	1410	95.587	0.692	6.6	0.9905	0.0000	SURCHARGED
1440 minute winter	S5	1410	95.587	0.883	8.6	1.2638	0.0000	SURCHARGED
1440 minute winter	S6	1410	95.587	0.916	8.5	0.0000	0.0000	OK
15 minute winter	S7	11	95.779	0.354	17.6	0.4005	0.0000	SURCHARGED
15 minute winter	S7-1	11	95.721	0.577	58.4	0.6521	0.0000	SURCHARGED
15 minute winter	S8	11	95.642	0.585	67.3	0.6622	0.0000	SURCHARGED
1440 minute winter	S9	1380	95.588	0.815	10.6	0.9216	0.0000	SURCHARGED
1440 minute winter	S10	1410	95.587	0.162	0.5	0.2321	0.0000	OK
1440 minute winter	S11	1410	95.587	0.357	1.2	0.5111	0.0000	OK
15 minute winter	S12	11	96.094	0.091	14.6	0.1028	0.0000	OK
1440 minute winter	S13	1410	95.587	0.892	10.5	0.0000	0.0000	OK
1440 minute winter	S14	1410	95.584	0.889	8.0	482.7417	0.0000	FLOOD RISK
30 minute summer	S15	118	94.682	0.039	2.6	0.0000	0.0000	OK
15 minute summer	S16	1	96.270	0.000	0.0	0.0000	0.0000	OK

Link Event (Upstream Depth)	US Node	Link	DS Node	Outflow (l/s)	Velocity (m/s)	Flow/Cap	Link Vol (m <sup>3</sup> )
15 minute winter	S1	1.000	S2	29.6	0.859	0.807	2.3862
15 minute winter	S2	1.001	S3	45.9	1.177	1.181	1.2491
1440 minute winter	S3	1.002	S4	3.8	0.490	0.054	0.9789
1440 minute winter	S4	1.003	S5	6.4	0.367	0.058	4.1441
1440 minute winter	S5	1.004	S6	8.5	0.221	0.053	2.0808
15 minute winter	S7	4.000	S7-1	18.9	0.479	0.525	2.3003
15 minute winter	S7-1	4.001	S8	55.3	1.389	1.509	0.0982
15 minute winter	S8	4.002	S9	69.7	0.990	0.987	4.8913
1440 minute winter	S9	4.003	S13	10.5	0.447	0.149	0.8509
1440 minute winter	S10	2.000	S11	0.5	0.255	0.005	4.8948
1440 minute winter	S11	2.001	S4	1.2	0.139	0.005	2.6031
15 minute winter	S12	3.001	S5	13.5	0.910	0.340	0.9760
1440 minute winter	S14	5.000	S15	2.6	0.557	0.066	0.0414
15 minute summer	S16	3.000	S12	0.0	0.000	0.000	0.3358

## Appendix F : Road Safety Audit



**ROAD SAFETY AUDIT REPORT**  
**CLIENT: DBFL CONSULTING ENGINEERS**  
**PROJECT TITLE: WHITESTOWN WAY TALLAGHT**  
**REV 0**

## Contents

1.0	Introduction & Description of the Scheme .....	1
2.0	Road Safety Audit Team.....	1
3.0	Road Safety Audit Information .....	1
4.0	Information provided to the Audit Team.....	1
5.0	Terms of Reference.....	1
6.0	Items Arising from Audit .....	1
6.1	Problem: Lack of visibility at pedestrian crossing.....	2
6.2	Problem: Substandard Pedestrian Crossing.....	3
6.3	Problem: Lack of pedestrian crossing facilities.....	4
6.4	Problem: Trees Obscuring visibility splay .....	5
6.5	Problem: Lack of turning point for bin truck or emergency services .....	6
	Audit Team Statement.....	7
	Road Safety Audit Feedback Form.....	8

[john@rycoengineering.ie](mailto:john@rycoengineering.ie)

tel: 087 -9064389

### 1.0 Introduction & Description of the Scheme

This report is a Stage 1 Road Safety Audit of the proposed development at Whitestown Way Tallaght, Dublin.

### 2.0 Road Safety Audit Team

The Road Safety Audit Team members were as follows:

Position	Name	TII Auditor Number
Team Leader	John Ryan BEng CEng MSc BE FConsEI	JR*101
Team Member	Ludmila Trindade dos Santos BEng CEng	LT LT 7440162

### 3.0 Road Safety Audit Information

The audit comprised an examination of the drawings supplied by DBFL Consulting Engineers, and a daylight site visit undertaken on 17<sup>th</sup> April 2026, where the area was driven and walked where appropriate in all directions. During the visits there was no rain, and the surface was dry. Traffic was moderate, pedestrian and cyclist numbers were low.

### 4.0 Information provided to the Audit Team

The following documents were provided to the audit team as part of the audit.

Document Number	Document Title	Revision
240192-X-04-Z00-DTM-DR-DBFL-CE-1001	Road Layout	0
240192-X-04-Z00-XXX-DR-DBFL-CE-5201	Typical Road Construction Details Sheet 1	0
240192-X-04-Z00-XXX-DR-DBFL-CE-5202	Typical Road Construction Details Sheet 2	0
240192-X-04-Z00-XXX-DR-DBFL-CE-5203	Typical Road Construction Details Sheet 3	0

### 5.0 Terms of Reference

The audit has been carried out following the guidance issued in TII documents GE-STY-01024 Road Safety Audit and GE-STY-1027 Road Safety Audit Guidance.

### 6.0 Items Arising from Audit

The following road safety problems were identified by the audit team when studying the provided information and on the subsequent site visit.

**6.1 Problem: Lack of visibility at pedestrian crossing**

**Location: Southwest corner of site**

Intervisibility between pedestrians and approaching vehicles at the proposed crossing may be obstructed by vehicles parking within adjacent parking spaces. Restricted visibility may reduce driver awareness of pedestrians waiting to cross or already on the crossing, increasing the risk of vehicle–pedestrian collisions.

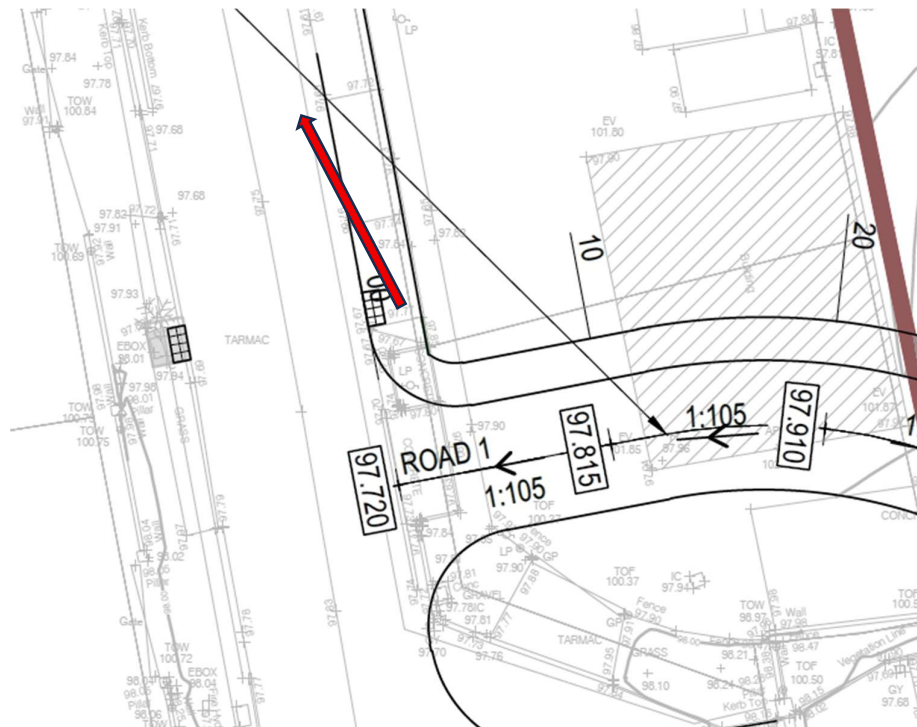

Figure 6.1 Proposed Layout

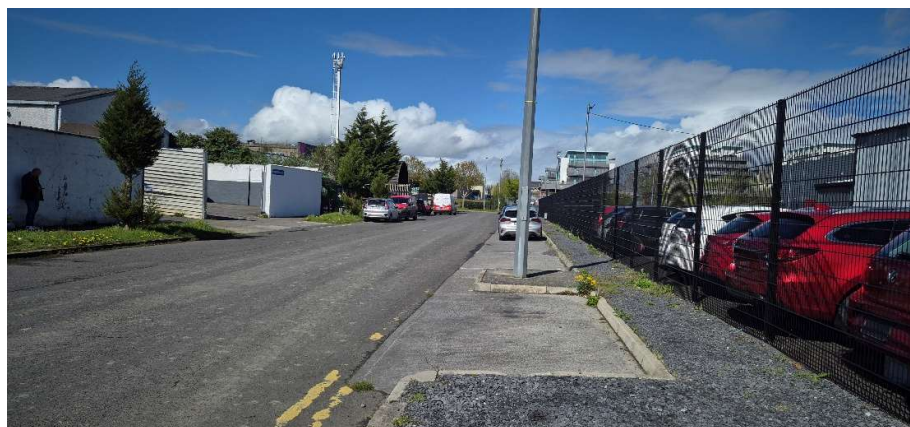

Figure 6.2 Existing Layout

**Recommendation**

The parking should be set back at the pedestrian crossing to ensure appropriate visibility is provided at the crossing.

## 6.2 Problem: Substandard Pedestrian Crossing

### Location: Crossing of Shopping Centre Access Road

The existing pedestrian crossing provision is substandard for its location, and its usage is likely to increase as a result of the proposed development. The inadequacy of the crossing facility may increase the potential for conflict between vulnerable road users crossing the carriageway and vehicular traffic entering and exiting the shopping centre, thereby elevating the risk of collisions.



Figure 6.3 Proposed Layout



Figure 6.4 Existing Layout

### Recommendation

Appropriate pedestrian crossing facilities should be provided.

### 6.3 Problem: Lack of pedestrian crossing facilities

#### Location: Arena Shopping Centre

A likely pedestrian desire line exists between the shared surface within the shopping centre and the entrance located to the northwest; however, no formal pedestrian crossing facility is proposed at this location. Pedestrians may cross informally along this desire line, resulting in potential conflict between vulnerable road users and vehicular traffic and increasing the risk of collisions.

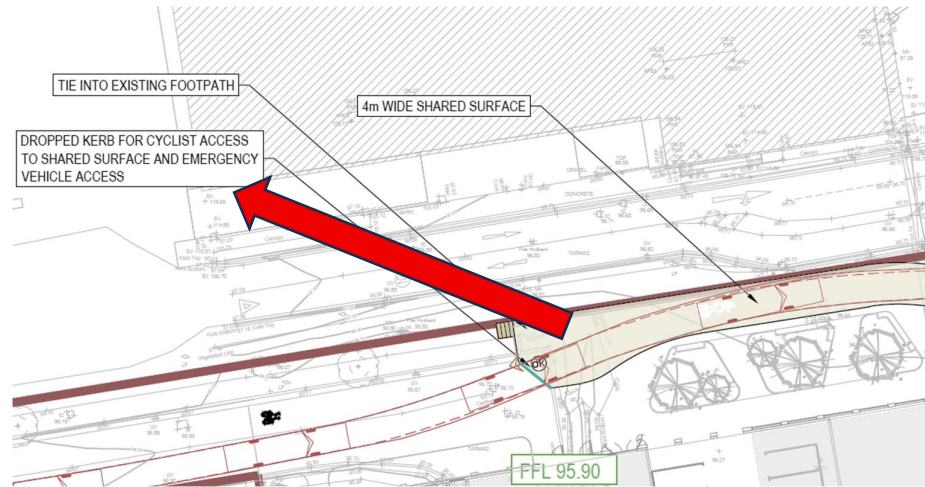

Figure 6.5 Proposed Layout

#### Recommendation

Appropriate pedestrian crossing facilities should be provided to accommodate the identified pedestrian desire line. Alternatively, the boundary fencing should be extended to direct pedestrians towards the formal crossing point on Whitestown Way and discourage informal crossing movements.

#### 6.4 Problem: Trees Obscuring visibility splay

##### Location: Internal junction

Trees are proposed within the visibility splay of the junction and may obstruct driver visibility. Obstruction of the required visibility envelope may restrict a driver's view of approaching vehicles or cyclists, increasing the potential for side-swipe or other collision types at the junction.

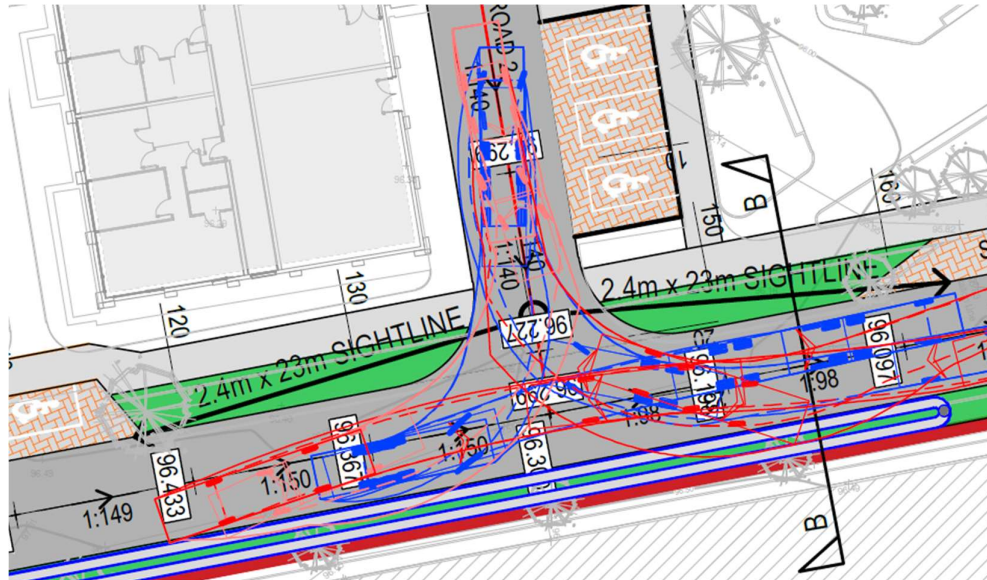

Figure 6.6 Proposed Layout

##### Recommendation

The proposed landscaping should be reviewed to ensure no planting encroaches into required visibility splays. Any necessary planting should be relocated or omitted to maintain clear visibility. Where trees are provided near the junction, species with a high canopy and minimal trunk girth at maturity should be selected to ensure visibility standards are maintained.

## 6.5 Problem: Lack of turning point for bin truck or emergency services

### Location: Internal layout

No turning facility has been provided within the development for service and emergency vehicles, including bin trucks and fire tenders. Service and emergency vehicles may be required to reverse out of the development, increasing the potential for conflicts with vulnerable road users and other vehicles, and elevating the risk of collision.

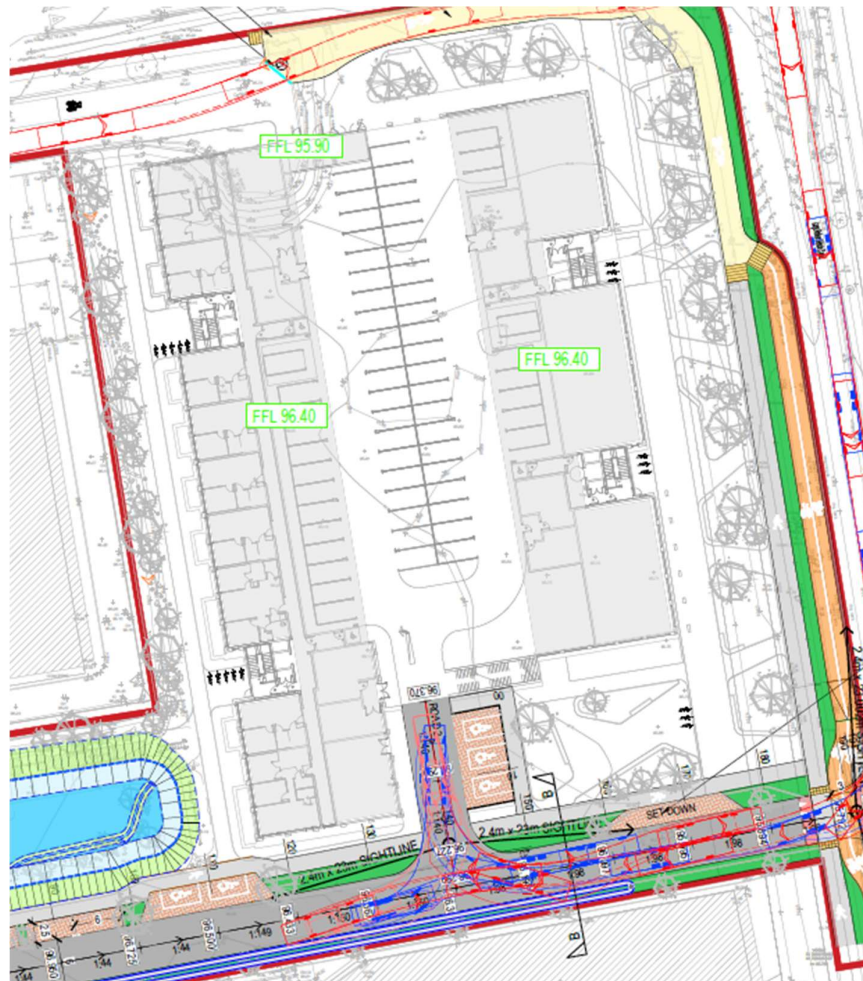

Figure 6.7 Proposed Layout

### Recommendation

A turning point should be provided for larger vehicles.

**Audit Team Statement**

We certify that we have examined the drawings listed in table 2 and visited the site during the day of 17<sup>th</sup> April. We further certify that we are independent from the design team for this scheme. This examination has been carried out with the sole purpose of identifying any features of the design that could be removed or modified to improve the safety of the scheme.

**Road Safety Audit Team Leader**

Name	John Ryan
Signed	
Qualification	MSc BEng CEng FconsEI
Position	Audit Team Leader
Date:	17/04/2026

**Road Safety Audit Team Member**

Name	Ludmila Trindade dos Santos
Signed	
Qualification	BEng CEng
Position	Audit Team Member
Date:	17/04/2026

## Road Safety Audit Feedback Form

Road Safety Audit Feedback Form	
Scheme: Whitestown Way Road Safety Audit	
Audit Stage: 1	Date of Audit 17/04/2026

To be Completed by Designer				To be Completed by Audit Team Leader
Item	Problem Accepted (yes/no)	Recommended measure accepted (yes/no)	Describe alternative measure(s) Give reasons for not accepting recommended measure. Only complete if recommended measure is not accepted.	Alternative measures or reasons accepted by auditors (yes/no)
6.1	Yes	No	This section of the road is not being delivered with this planning application as it is 3d party lands. The continuation on the drawing shows that our design does not prejudice the future delivery. The parking will be set back with appropriate visibility when the future extension of the link street is delivered.	Yes
6.2	Yes	Yes	Tactile paving will be upgraded on southern side of the crossing within the applicant's red line and the tactile on the northern side will be upgraded in conjunction with South Dublin County Council.	
6.3	Yes	No	This is third party lands. We propose to proceed with the continuation of boundary treatment. We acknowledge that there is a significant level change, as well as existing retaining wall, fence and trees but there is no place to land on the Arena side as there is no footpath on the south of the road.	Yes
6.4	Yes	Yes		
6.5	No	No	The car park shown is an under podium car park which forms part of the building. There is no access for refuse vehicles or emergency vehicles to the car park. Large refuse vehicle and emergency vehicle can turn at the car park entrance. A turning head has also been added at the western end of the link street until the street is made continuous to Whitestown Road in the future.	Yes

Signed Maire Doyle

Designer

Date 29/04/2026

Signed [Signature]

Audit Team Leader

Date 29/04/2026

Signed Adam Dunne

Employer

Date 15/05/26